

Doers Window
MANUFACTURING
4901 Oak Fair Blvd., Tampa, FL 33610

9450 Single Hung Window

IMPACT RATED w/ Flange

GENERAL NOTES

1. This product anchoring drawing has been evaluated and is in compliance with the 5th Edition (2014) Florida Building Code (FBC) excluding the "High Velocity Hurricane Zone" (HVHZ). See the Certification Agency Certificate for sizes, specifications & ratings.
2. Product anchors shall be as listed and spaced as shown on details. Anchor embedment to base material shall be beyond wall dressing or stucco.
3. When used in areas requiring wind borne debris protection, this product complies with Section 1609.1.2 of the FBC and does not require an impact resistant covering. This product meets missile level "D" and includes Wind Zone 4 as defined in ASTM E 1996 and Section 1609.1.2.2 of the FBC.
4. For 2x stud framing construction, anchoring of these units shall be the same as that shown for 2x buck masonry construction.
5. Site conditions that deviate from the details of this drawing require further engineering analysis by a licensed engineer or registered architect.

TABLE OF CONTENTS

SHEET#	DESCRIPTION
1	Typical elevations, design pressures & general notes
2	Vertical & horizontal cross sections
3	Buck & frame anchoring
4	Components
5	Bill of materials and glazing details

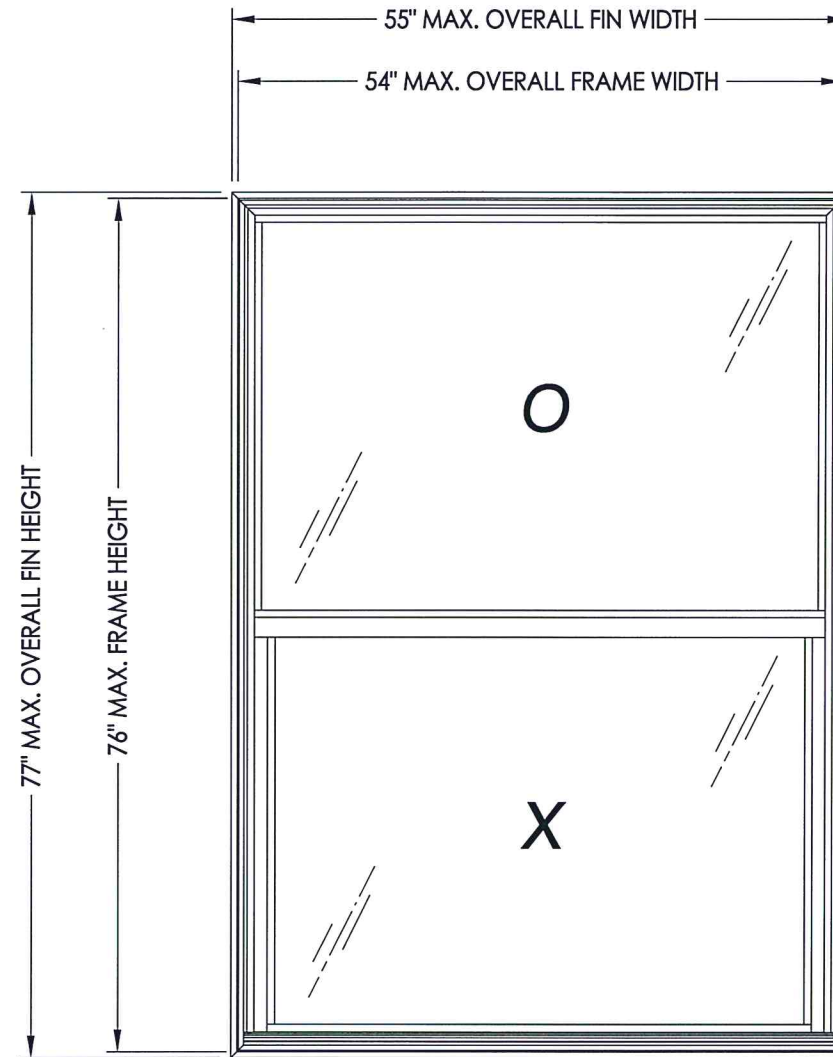

MAX. OVERALL FIN DIMENSION	MAX. OVERALL FRAME DIMENSION	MAX DAY LITE DIMENSION (OPERABLE)	MAX DAY LITE DIMENSION (FIXED)	GLASS TYPE	DESIGN PRESSURE (PSF)	
					POS.	NEG.
55.0" X 77.0"	54.0" X 76.0"	47.25" x 34.38"	49.75" x 34.5"	G1	+55.0	-65.0

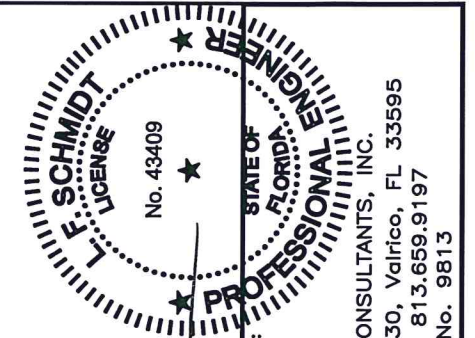

Documents Prepared By:
Lyndon F. Schmidt
P.E. No. 43409

R.W. BUILDING CONSULTANTS, INC.
P.O. Box 230, Valrico, FL 33595
Phone No.: 813.659.9197
FBPE C.A. No. 9813

PRODUCT: SINGLE HUNG WINDOW

PART OR ASSEMBLY:
TYPICAL ELEVATION, DESIGN
PRESSURES & GENERAL NOTES

NO.	DATE	REVISIONS
1	6/26/15	UPDATE TO 5TH ED. (2014) FBC

DATE: 2/19/14
SCALE: N.T.S.
DWG. BY: JK
CHK. BY: LFS
DRAWING NO.: FL-16854.4
SHEET 1 OF 5

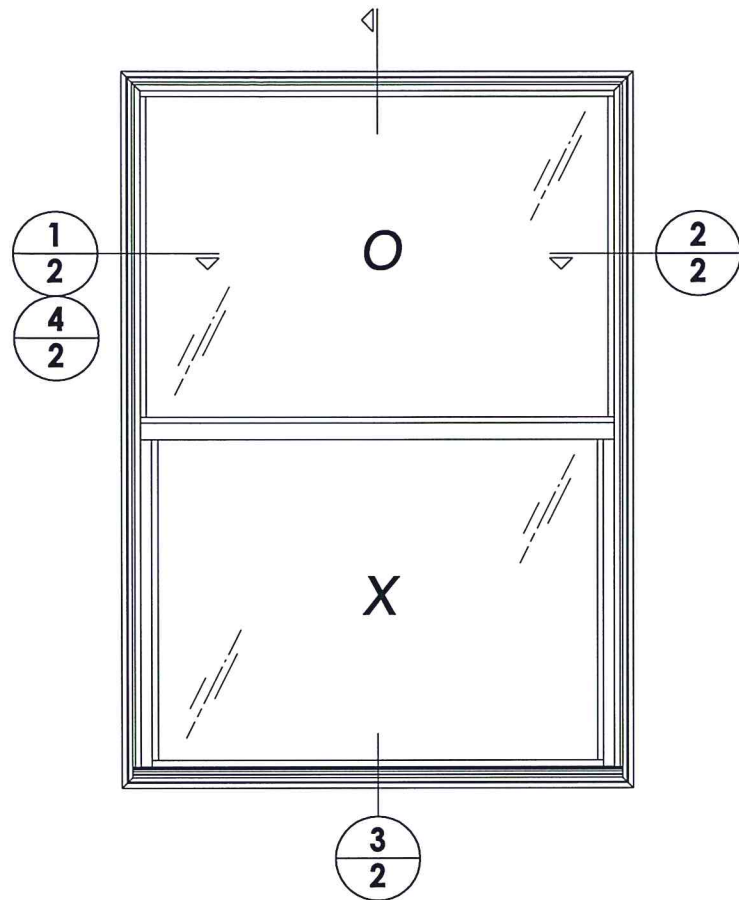

Note:
1. Lock and keeper located 7" from each end of lock/meeting rail.

NOTE: Sheet Metal Screws must penetrate a min. of 3 threads through at least 2 sheets of metal.

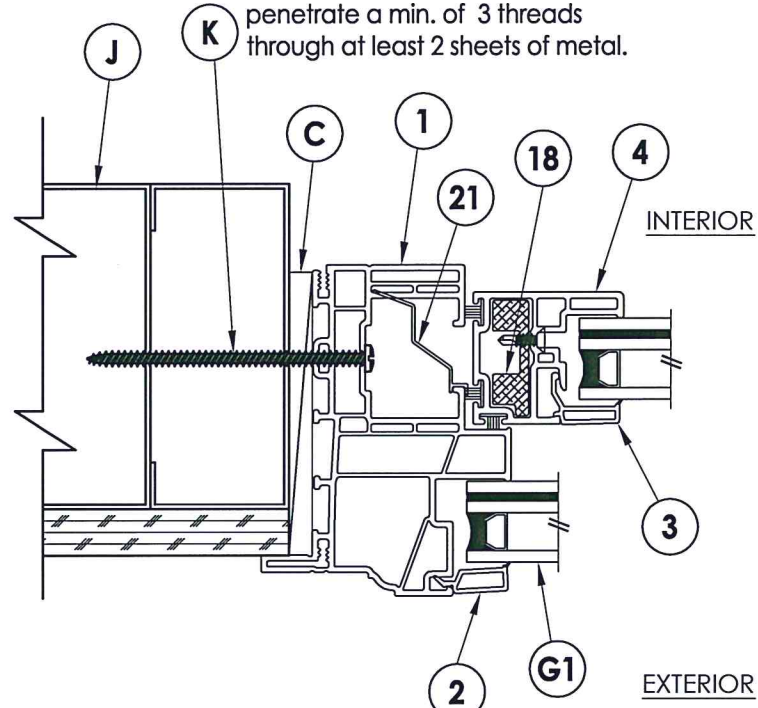

4 HORIZONTAL CROSS SECTION
2 Metal Stud Construction

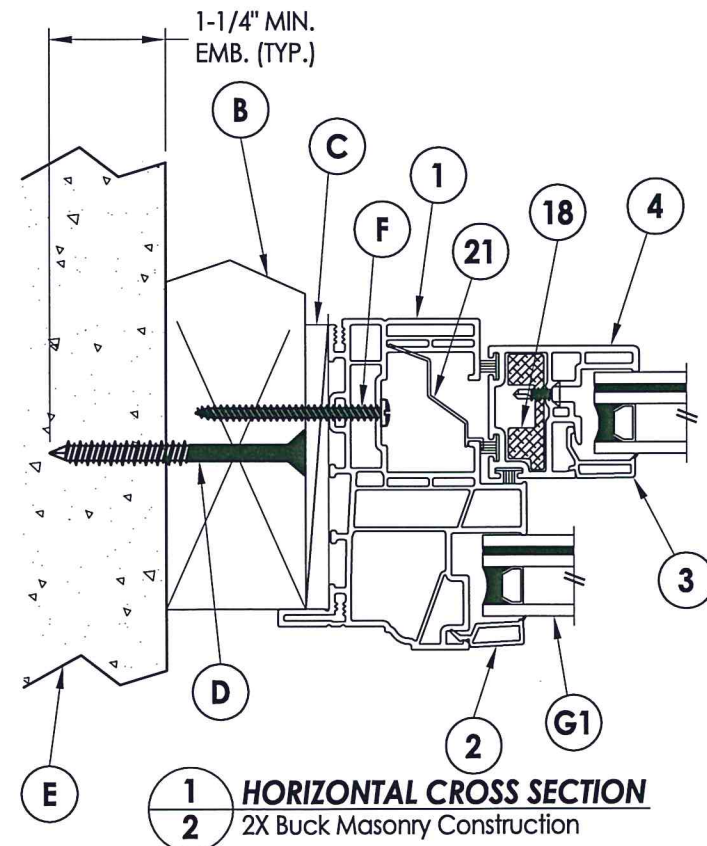

1 HORIZONTAL CROSS SECTION
2 2X Buck Masonry Construction

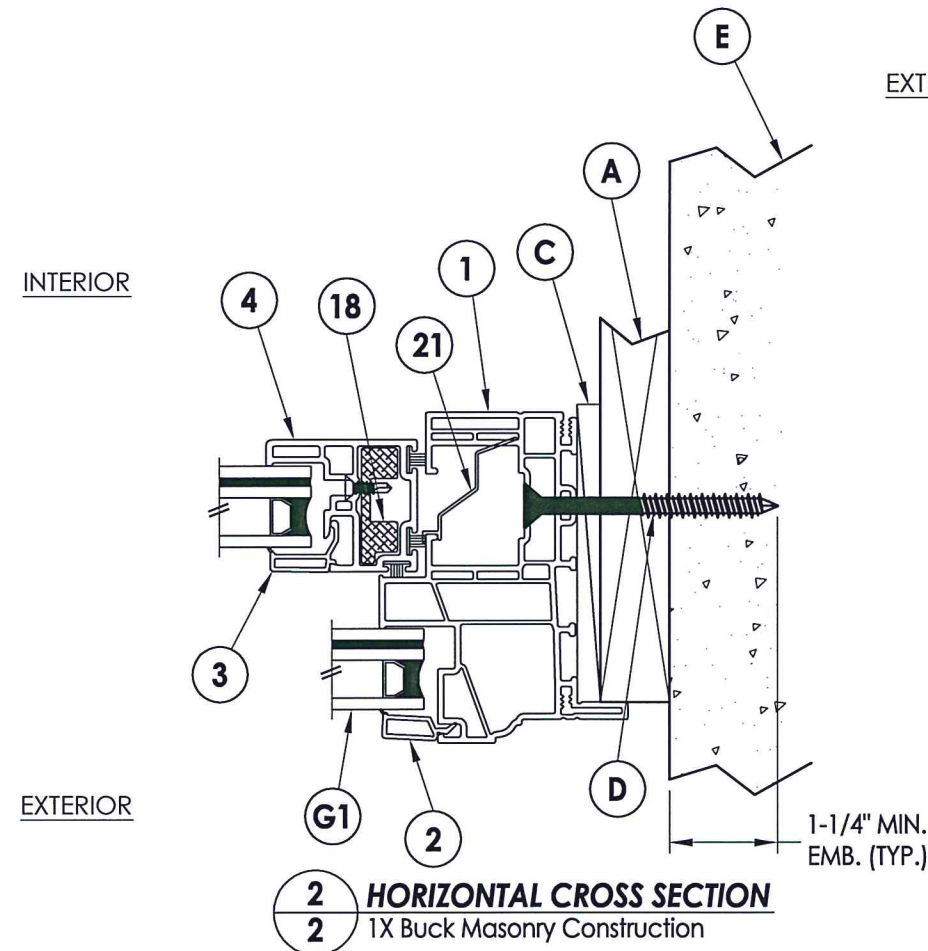

2 HORIZONTAL CROSS SECTION
2 1X Buck Masonry Construction

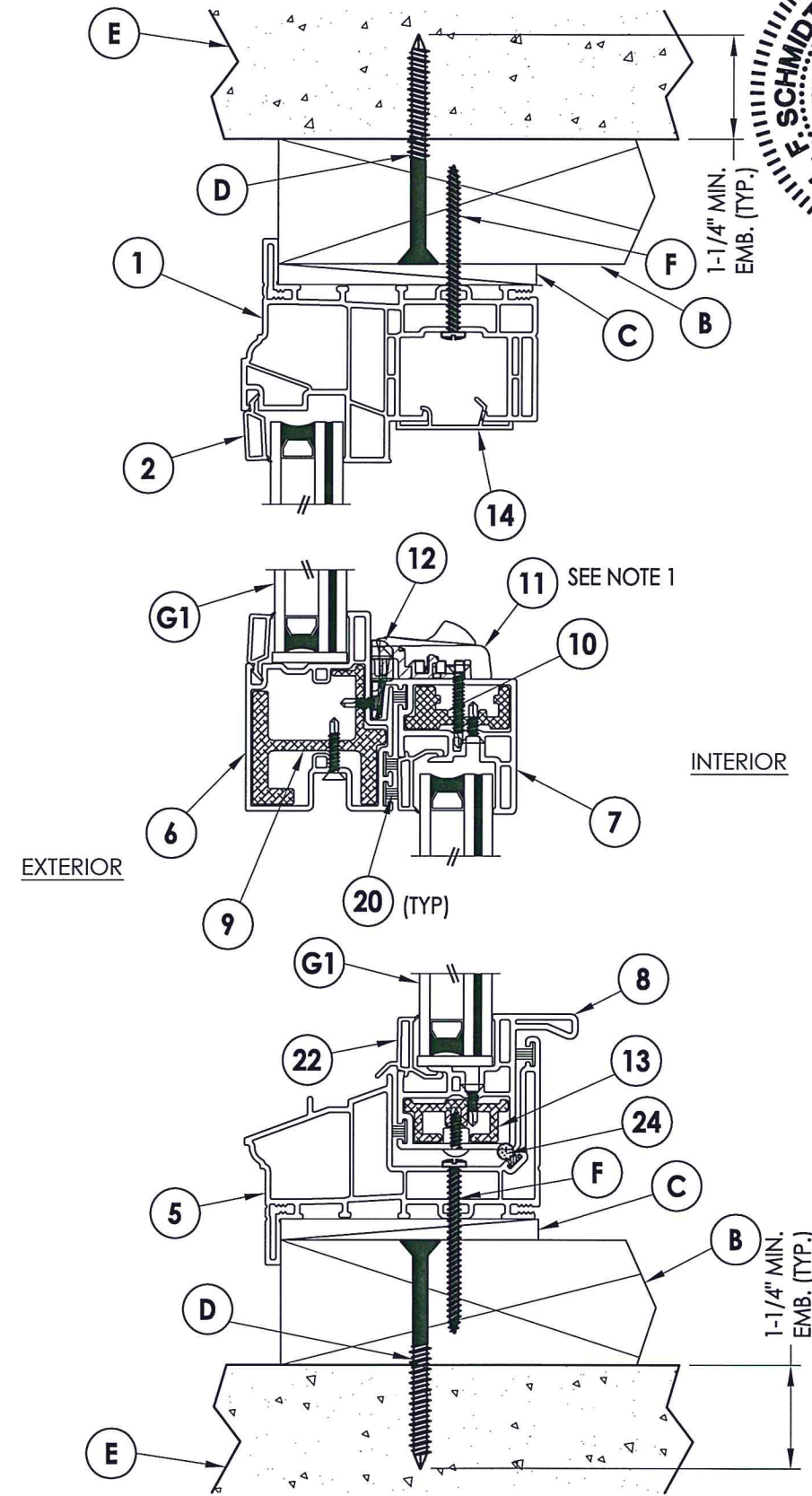

3 VERTICAL CROSS SECTION
2 2X Buck Masonry Construction

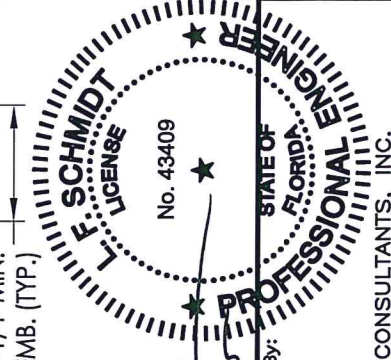

Documents Prepared By:
Lyndon F. Schmidt
P.E. No. 43409

RW BUILDING CONSULTANTS, INC.
P.O. Box 230, Valrico, FL 33595
Phone No.: 813.659.9197
FBPE C.A. No. 9813

PRODUCT:	SINGLE HUNG WINDOW	
PART OR ASSEMBLY:	VERTICAL & HORIZONTAL CROSS SECTIONS	
DATE:	2/19/14	
SCALE:	N.T.S.	
DWG. BY:	JK	
CHK. BY:	LFS	
DRAWING NO.:	FL-16854.4	
SHEET	2 OF 5	
NO.	DATE	REVISIONS
1	6/26/15	UPDATE TO 5TH ED. (2014) FBC
		LFS BY

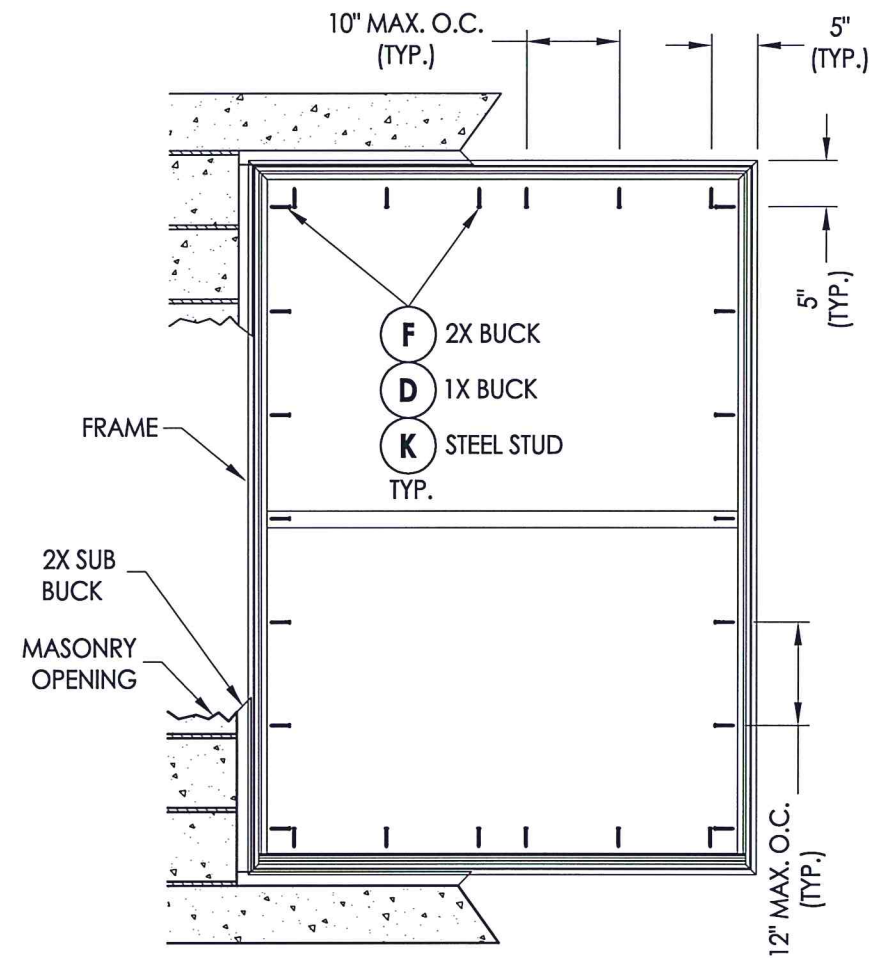
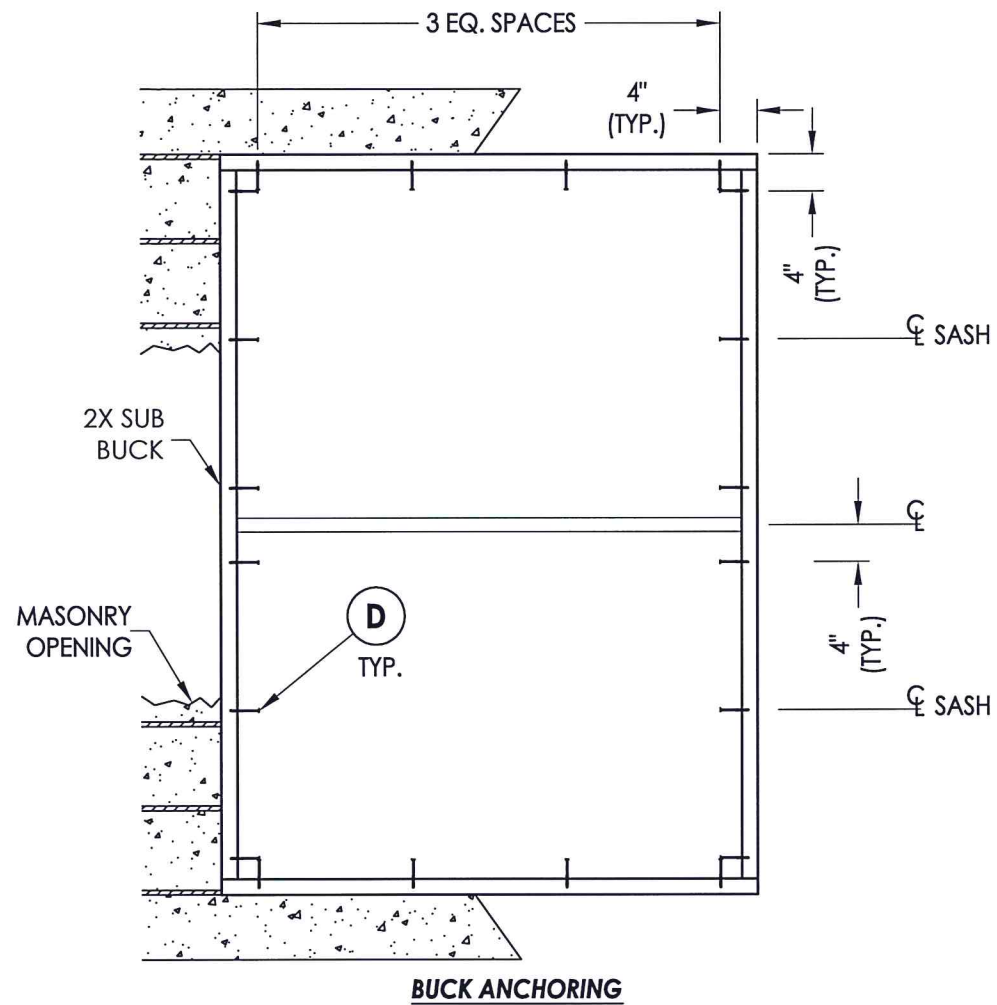

CONCRETE ANCHOR NOTES:

1. Concrete anchor locations at the corners may be adjusted to maintain the min. edge distance to mortar joints.
2. Concrete anchor locations noted as "MAX. ON CENTER" must be adjusted to maintain the min. edge distance to mortar joints, additional concrete anchors may be required to ensure the "MAX. ON CENTER" dimension are not exceeded.
3. Concrete anchor table:

ANCHOR TYPE	ANCHOR SIZE	MIN. EMBEDMENT	MIN. CLEARANCE TO MASONRY EDGE	MIN. CLEARANCE TO ADJACENT ANCHOR
ITW TAPCON®	1/4"	1-1/4"	2"	4"
ELCO ULTRACON®	1/4"	1-1/4"	1"	4"

WOOD SCREW INSTALLATION NOTES:

1. Maintain a minimum 5/8" edge distance, 1" end distance, & 1" o.c. spacing of wood screws to prevent the splitting of wood.

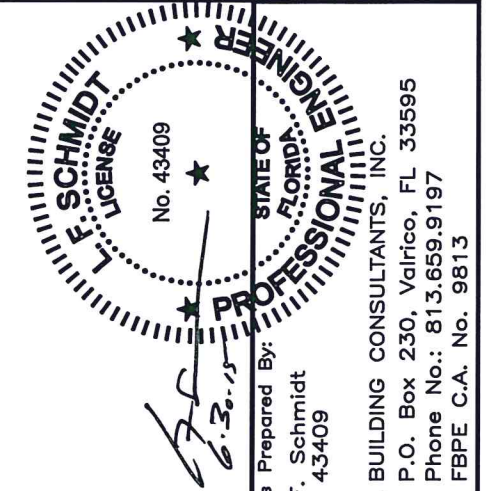

Documents Prepared By:
 Lyndon F. Schmidt
 P.E. No. 43409
 R.W. BUILDING CONSULTANTS, INC.
 P.O. Box 230, Valrico, FL 33595
 Phone No.: 813.659.9197
 FBPE C.A. No. 9813

PRODUCT: SINGLE HUNG WINDOW
 PART OR ASSEMBLY: BUCK & FRAME ANCHORING

NO.	DATE	REVISIONS
1	6/26/15	UPDATE TO 5TH ED. (2014) FBC
		LFS
		BY

DATE: 2/19/14
 SCALE: N.T.S.
 DWG. BY: JK
 CHK. BY: LFS
 DRAWING NO.: FL-16854.4
 SHEET 3 OF 5

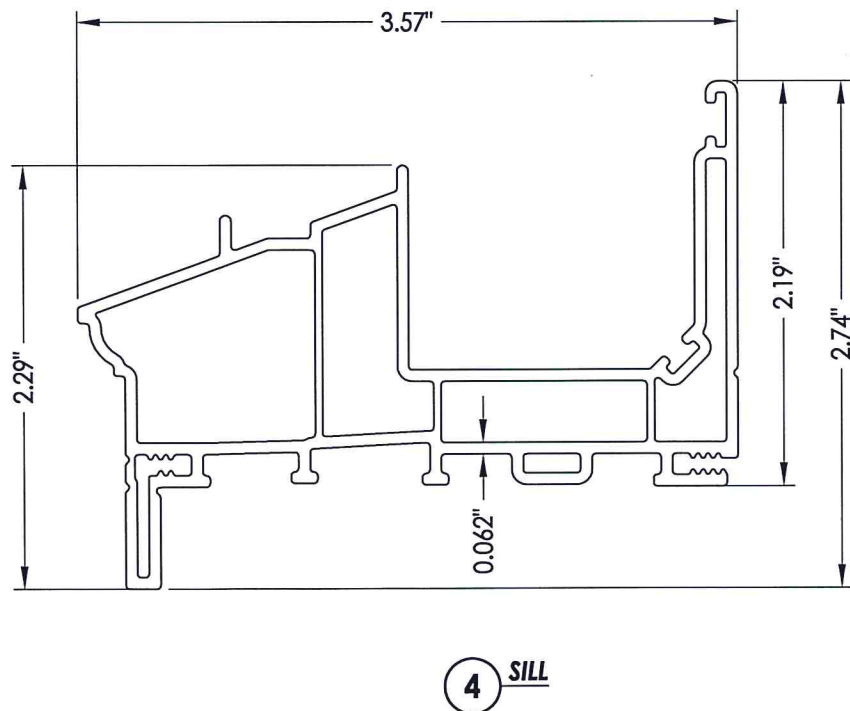

4 SILL

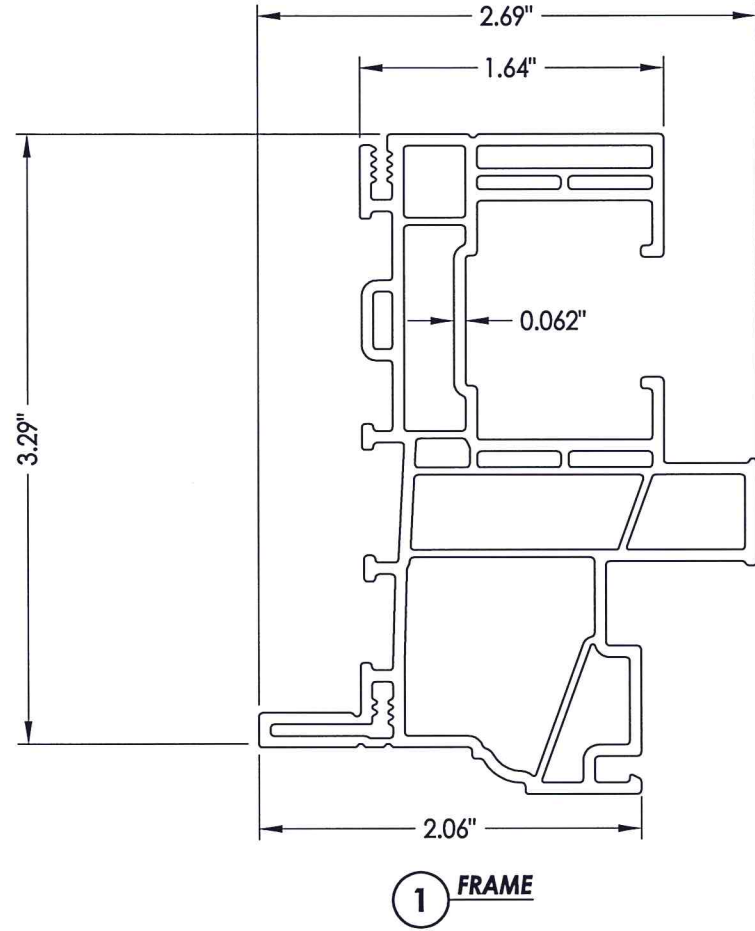

1 FRAME

18 STILE REINFORCEMENT

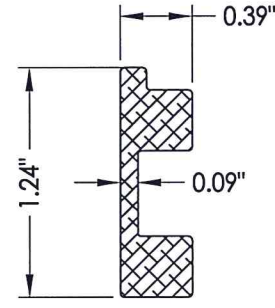

10 LOCK RAIL REINFORCEMENT

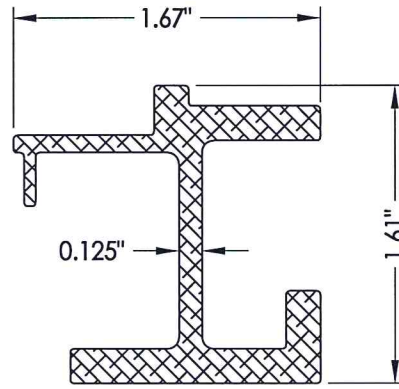

9 MEETING RAIL REINFORCEMENT

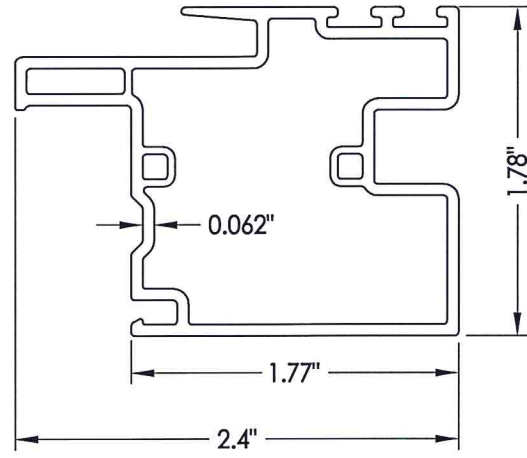

6 MEETING RAIL

13 BOTTOM RAIL REINFORCEMENT

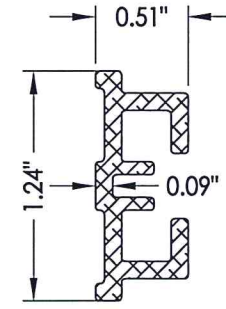

2 GLAZING BEAD

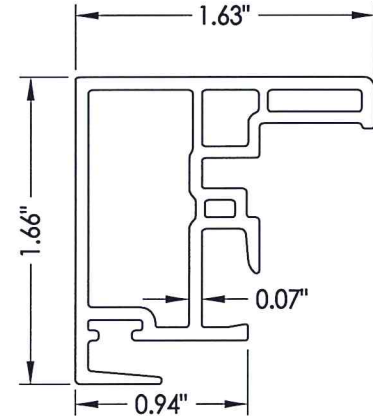
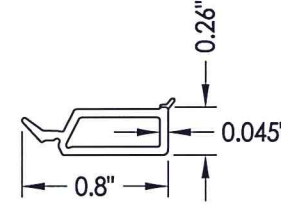

7 LOCK RAIL

3 GLAZING BEAD

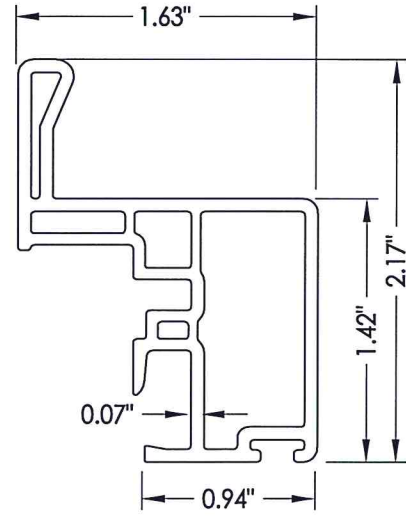
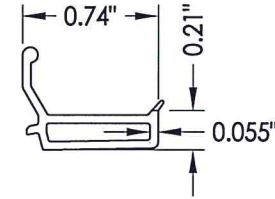

8 BOTTOM RAIL

22 GLAZING BEAD W/ Drip edge

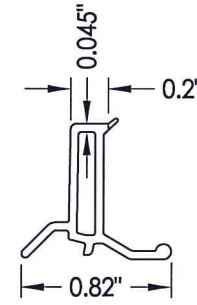

5 STILE

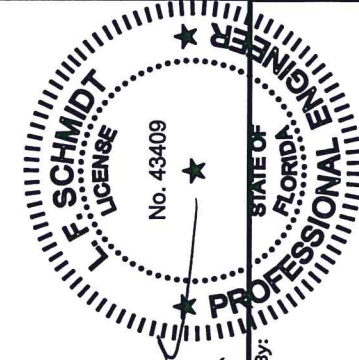
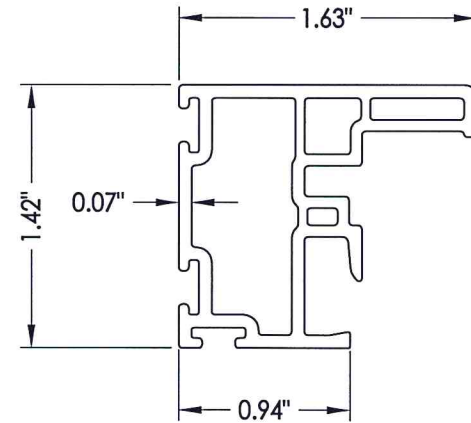

Documents Prepared By:
Lyndon F. Schmidt
P.E. No. 43409

R.W. BUILDING CONSULTANTS, INC.
P.O. Box 230, Valrico, FL 33595
Phone No.: 813.659.9197
FBPE C.A. No. 9813

PRODUCT: SINGLE HUNG WINDOW
PART OR ASSEMBLY: COMPONENTS

REVISIONS	
NO.	DATE
1	6/26/15
	UPDATE TO 5TH ED. (2014) FBC
	LFS
	BY

DATE: 2/19/14
SCALE: N.T.S.
DWG. BY: JK
CHK. BY: LFS
DRAWING NO.: FL-16854.4
SHEET 4 OF 5

BILL OF MATERIALS

ITEM #	DESCRIPTION	MATERIAL
B	2X BUCK (SG >= 0.55)	WOOD
C	1/4" MAX. SHIM SPACE	-
D	1/4" X 2-3/4" PFH ELCO OR ITW CONCRETE SCREW	STEEL
E	MASONRY - 3,000 PSI MIN. CONCRETE CONFORMING TO ACI 301 OR HOLLOW BLOCK CONFORMING TO ASTM C90	CONCRETE
F	#10 X 2" PPH SMS	STEEL
G	2X STUD (SG >= 0.55)	WOOD
H	#10 X 2-1/2" PPH SMS	STEEL
J	STEEL STUD Min. Thk .033" (ASTM A653 GRADE 33 Fy=33 ksi min., Fu=45 ksi min.)	STEEL
K	#10 PPH SELF-DRILLING SMS	STEEL
1	EXTRUDED VINYL FRAME (465)*	RIGID PVC
2	EXTRUDED VINYL GLAZING BEAD (736A)*	RIGID PVC
3	EXTRUDED VINYL GLAZING BEAD (425A)*	RIGID PVC
4	SILL (469)*	RIGID PVC
5	STILE (438)*	RIGID PVC
6	MEETING RAIL (477)*	RIGID PVC
7	LOCK RAIL (476)*	RIGID PVC
8	BOTTOM RAIL (485B)*	RIGID PVC
9	MEETING RAIL REINFORCEMENT	6063 - T5 ALUM
10	LOCK RAIL REINFORCEMENT	6063 - T5 ALUM
11	SASH LOCK	-
12	KEEPER	-
13	BOTTOM RAIL REINFORCEMENT	6063 - T5 ALUM
14	HEAD ADAPTER (473)*	RIGID PVC
18	STILE REINFORCEMENT	6063 - T5 ALUM
20	WEATHERSTRIP	-
21	BALANCE COVER (468)	RIGID PVC
22	EXTRUDED VINYL GLAZING BEAD W/ DRIP EDGE (467)*	RIGID PVC
24	BULB GASKET (AMESBURY)	FOAM

* THE APPROVED WHITE RIGID PVC EXTERIOR EXTRUSIONS FOR WINDOWS ARE TO BE PRODUCED BY EXTRUDERS LICENSEES IN "AAMA CERTIFICATION PROGRAMS FOR RIGID PVC EXTRUSIONS".

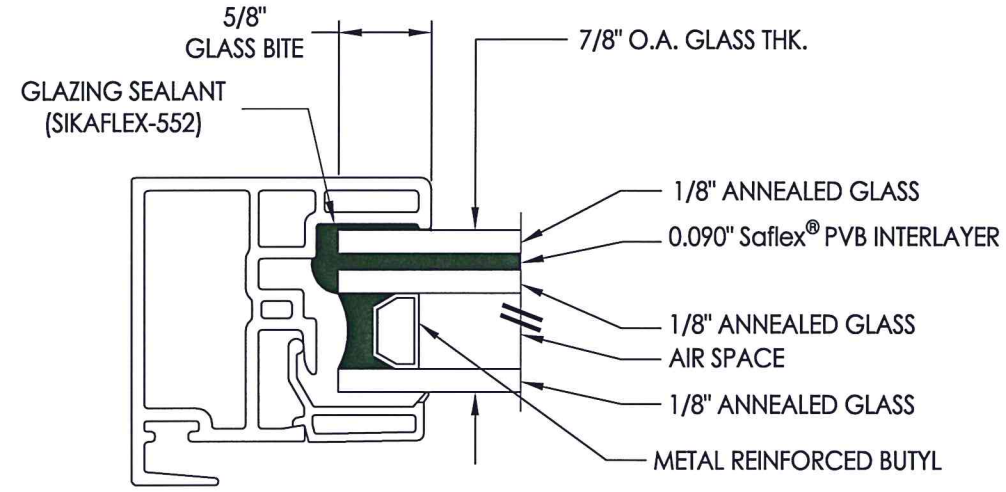

G1 GLAZING DETAIL

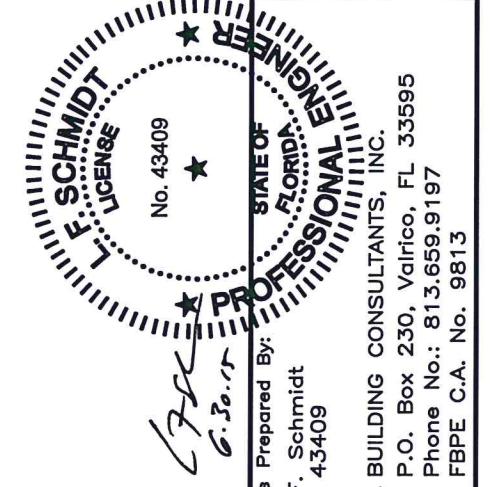

Documents Prepared By:
Lyndon F. Schmidt
P.E. No. 43409
RW
BUILDING CONSULTANTS, INC.
P.O. Box 230, Vairico, FL 33595
Phone No.: 813.659.9197
FBPE C.A. No. 9813

PRODUCT: SINGLE HUNG WINDOW
PART OR ASSEMBLY: BILL OF MATERIALS AND GLAZING DETAILS

NO.	DATE	DESCRIPTION	BY
1	6/26/15	UPDATE TO 5TH ED. (2014)	LFS

DATE: 2/19/14
SCALE: N.T.S.
DWG. BY: JK
CHK. BY: LFS
DRAWING NO.: FL-16854.4
SHEET 5 of 5